

# OHC 100 SERIES

## "A" TYPE END LOAD ARM INSTALLATION INSTRUCTIONS CENTER HUNG, DOUBLE OR SINGLE ACTION DOORS FOR 1" DEPTH TOP RAIL

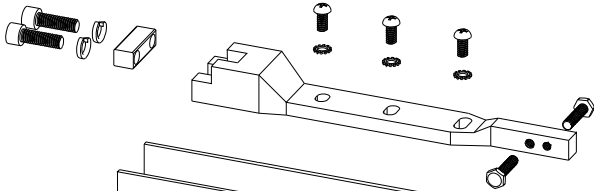

**NOTE:**  
FOR INSTALLATION OF CLOSER  
SEE CLOSER INSTRUCTION SHEETS.

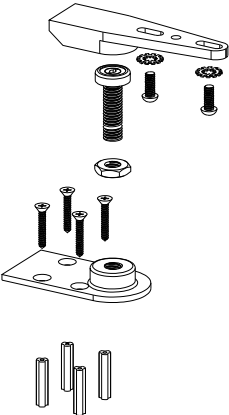
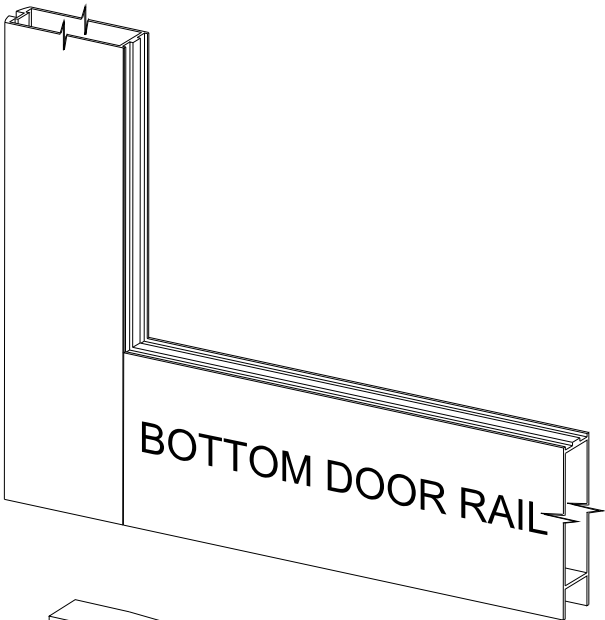

**CAUTION**  
IMPROPER INSTALLATION OR REGULATION MAY  
RESULT IN PERSONAL INJURY OR PROPERTY DAMAGE.  
FOLLOW ALL INSTRUCTIONS CAREFULLY. FOR  
QUESTIONS, CALL Dor-O-Matic AT 1-800-815-1517



## TOP DOOR RAIL

### "A" Type End Loading Arm for 1" depth Top Rail

#### Steps for Installation:

1. Make a 1" deep cut-out in butt of door (see Fig. 1).
2. Drill or drill and tap holes in top of door, as shown.
3. Position arm in door by placing arm pin in 3/16" hole.
4. Install arm using three 1/4-20 x 5/8" pan head machine screws and lock washers. Center arm in the top rail by adjusting the two 1/4-20 x 1" hex head centering bolts.

**Note:** After door is installed, secure with clamp bar and the two 1/4-20 x 1" socket head clamp bar cap screws with locking washers. These must be tightened securely.

## BOTTOM DOOR RAIL

### End Loading

1. Make cut out in butt of door equal to depth of the bottom rail (see Fig. 2).
2. Drill and tap 1/4-20 holes in bottom rail of door, as shown.
3. Install pivot bearing retainer in bottom of door using two 1/4-20 x 5/8" pan head machine screws and lock washers.
4. Laterally adjust center of pivot bearing retainer 2 5/8" from butt of door (not including weatherstripping) and tighten screws securely.

**NOTE:** For shallow bottom rail depth, the pivot bearing stud may be shortened by sawing off at undercut 1/2" from bottom.

## FLOOR MOUNT PIVOT

1. Position pivot base against door jamb on hinge side. Mark and drill 1/4" holes 1 1/2" deep in floor for plastic expansion plugs.
2. Mount base using #12 x 1 1/4" plastic expansion plugs and #12 x 1 1/4" flat head wood screws.
3. Install pivot stud and bearing with 1/2-20 hex lock nut, as shown and adjust bearing height for proper door clearance and firmly tighten lock nut.
4. When using threshold, drill 1 1/4" hole for clearance of pivot base on center line 2 3/4" from hinge end of threshold.

When threshold is not used, pivot bearing stud must be shortened by sawing off at undercut 1/2" from bottom.

## THRESHOLD MOUNT PIVOT

1. Drill 3/4" hole in threshold, as shown.
2. Install threshold adapter nut from top and secure with 3/4-16 hex jamb nut underneath.
3. Install pivot stud and bearing with 1/2-20 hex lock nut, as shown and adjust bearing height for proper door clearance and firmly tighten lock nut.

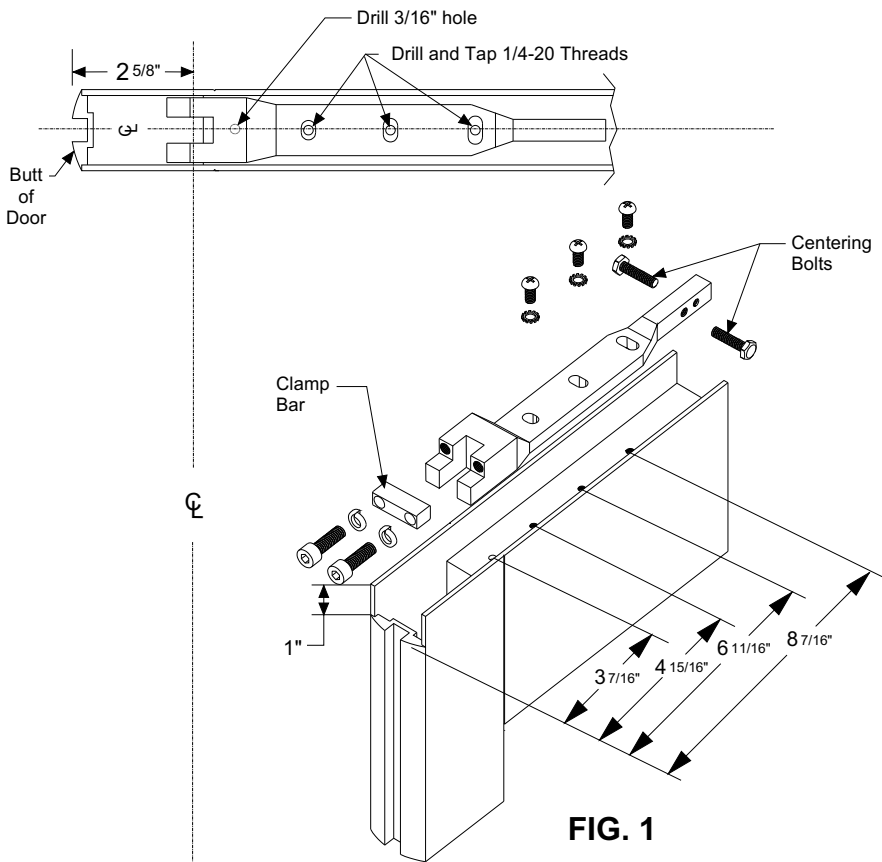

**FIG. 1**

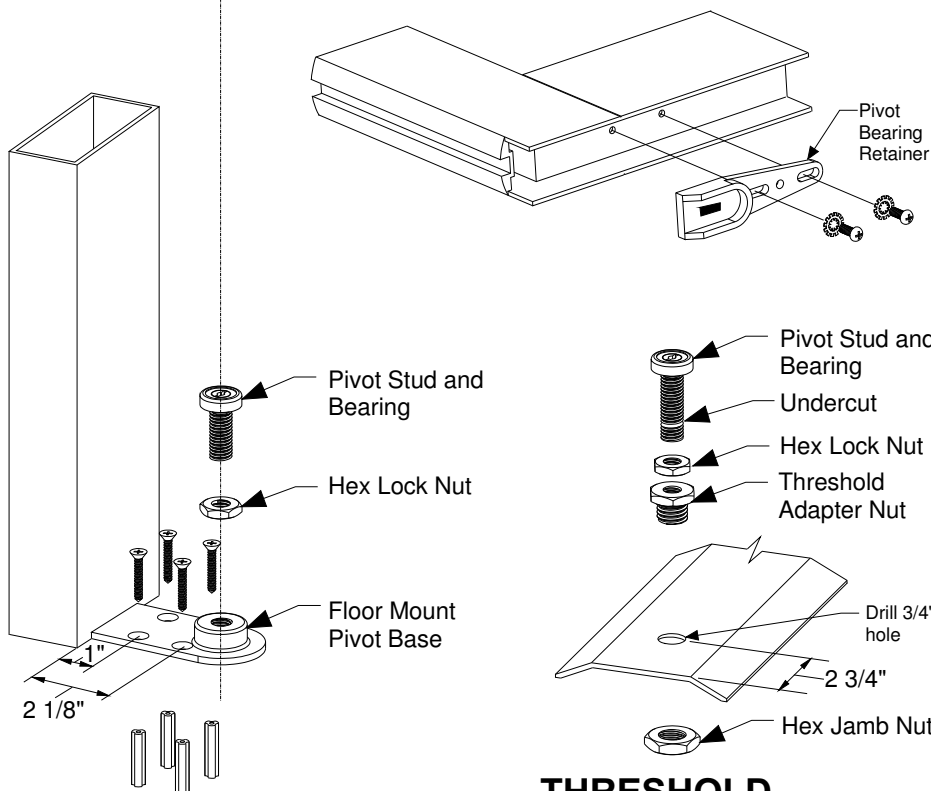
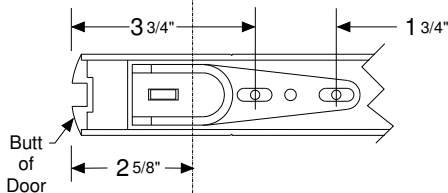

**FLOOR MOUNT PIVOT**

**THRESHOLD MOUNT PIVOT**