

# FERME-PORTE SÉRIE SC 71

## INSTRUCTIONS D'INSTALLATION

Modèles avec bras Spring-N-Stop & Spring-N-Stop/avec retenue

SC71 (1-6 Adj.)

# SC 71 SERIES DOOR CLOSER

## INSTALLATION INSTRUCTION

Spring-N-Stop & Spring-N-Stop/Hold Open Arm Models

SC71 (1-6 Adj.)

# CERRADOR DE PUERTA SERIE SC 71

## INSTRUCCIONES DE INSTALACIÓN

Modelos con brazo Spring-N-Stop & Spring-N-Stop/con retención

SC71 (1-6 Adj.)

**Parallel Arm Closer mounted on push side of door.**  
**Installation** (Opposite of the hinge side)

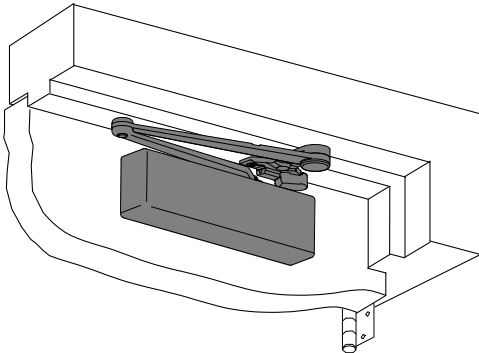

**Installation "bras parallèle"** Ferme-porte installé sur le côté à pousser de la porte. (À l'opposé du côté de la charnière)  
**Instalación "brazo paralelo"** Cerrador montado a lado del empuje de la puerta. (Opuesto al lado del gozne)

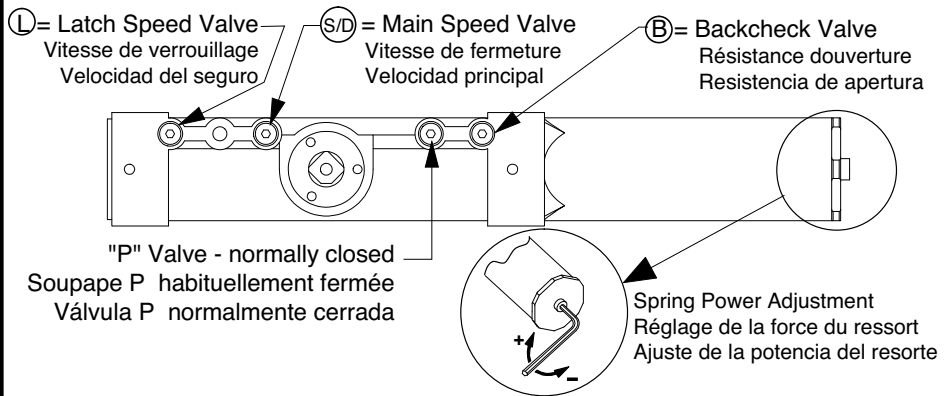

(Optional)

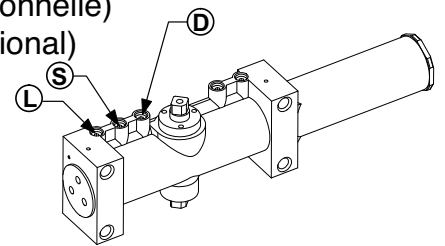

(Optionnelle)

(Opcional)

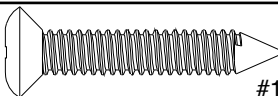
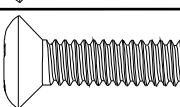
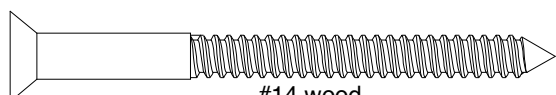
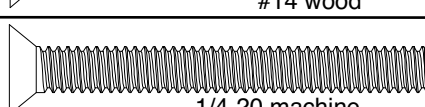
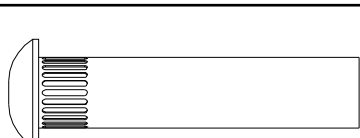
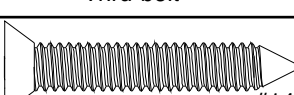
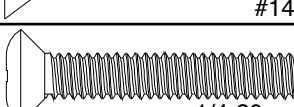
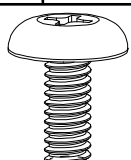
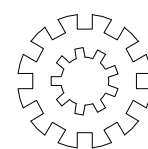

**D** = Delay Action Valve (Optional)  
 Soupape de retardement (Optionnelle)  
 Válvula de retardación (Opcional)

### FASTENERS

		DOOR / FRAME	DRILL-SIZES
ARM SHOE	 #14 wood	WOOD	1/8"
	 1/4-20 machine	METAL	drill: #7 tap: 1/4-20
CLOSER BODY	 #14 wood	WOOD	1/8"
	 1/4-20 machine	METAL	drill: #7 tap: 1/4-20
EITHER	 Thru-bolt	ALL	3/8"
FIFTH HOLE SPACER	 #14 wood	WOOD	1/8"
	 1/4-20 machine	METAL	drill: #7 tap: 1/4-20
	 ARM ATTACHMENT SCREW		
	 ARM ATTACHMENT LOCK WASHER		
	 COVER SCREW		
	 COVER PLUG		

**CAUTION**

IMPROPER INSTALLATION OR REGULATION MAY RESULT IN PERSONAL INJURY OR PROPERTY DAMAGE. FOLLOW ALL INSTRUCTIONS CAREFULLY. FOR QUESTIONS, CALL Dor-O-Matic AT 1-800-815-1517

**DANGER**

Une installation ou un réglage inadéquats peuvent entraîner des blessures ou des dommages. Veuillez suivre toutes les instructions avec soin. Pour plus de renseignements, composez le 1-800-815-1517

**ADVERTENCIA**

Una instalación o un ajuste incorrectos pueden resultar en daño personal o material. Siga bien todas las instrucciones. para más informaciones, llama a lcn al 1-800-815-1517

**Dor-O-Matic**

- 1. Door and Frame Preparation** A. Choose degree of door opening B. Drill per screw chart. (See front page)  
 Préparation de la porte et du cadre A.Sélectionnez le degré d'ouverture désiré B.Percez selon les indications du tableau (voir la page frontispice)  
 Preparación de la puerta y del cuadro A.Elija el grado de apertura de la puerta B.Barrene según el gráfico (Vea la página de la cubierta)

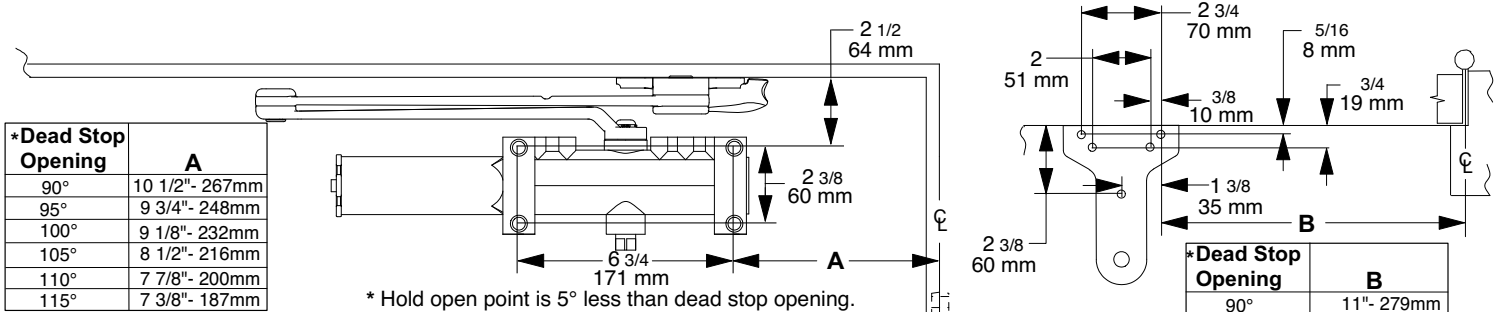

*Dead Stop Opening	A
90°	10 1/2" - 267mm
95°	9 3/4" - 248mm
100°	9 1/8" - 232mm
105°	8 1/2" - 216mm
110°	7 7/8" - 200mm
115°	7 3/8" - 187mm

*Dead Stop Opening	B
90°	11" - 279mm
95°	10 1/4" - 260mm
100°	9 5/8" - 244mm
105°	9" - 229mm
110°	8 3/8" - 213mm
115°	7 7/8" - 200mm

\* Hold open point is 5° less than dead stop opening.

**RIGHT HAND DOOR ILLUSTRATED.**

Same dimensions apply for Left Hand Door measured from center line of hinge.  
 PORTE MAIN DROITE ILLUSTRÉE. Les mêmes dimensions s'appliquent pour une porte main gauche, mesurées à partir du centre de la charnière.  
 PUERTA MANO DERECHA ILLUSTRADA. Las mismas dimensiones se aplican para puertas de mano izquierda, medidas a partir de la línea central de la bisagra.

**2. Determine door width, adjust spring power to match chart.**

Mesurez la largeur de la porte. Réglez le ressort selon les indications du tableau. Déterminez la largeur de la porte. Ajuste la potencia del resorte según lo indicado en el gráfico.

Door Width	Power Adjustment
32" - 815mm	+ 5
36" - 915mm	+ 9
42" - 1050mm	+ 15
48" - 1220mm	+ 21

\* Door closer is shipped with +9 turns.  
 Ferme-porte expédié avec +9 révolutions  
 Cerrador mandado con +9 vueltas

**3. Install closer onto door.**

Installez le ferme-porte sur la porte. Monte el cerrador en la puerta.

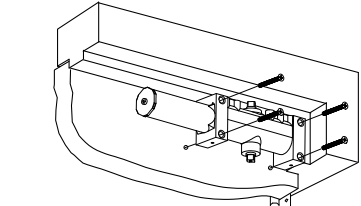

**Valves UP for Right hand door. (Shown)**  
**Valves DOWN for Left hand door.**  
 Soupapes vers le HAUT pour porte main droite (illustrée)  
 Soupapes vers le BAS pour porte main gauche  
 Válvulas ARRIBA para puerta mano derecha (ilustrada)  
 Válvulas ABAJO para puerta mano izquierda  
**Spring Power faces away from the hinge edge.**  
 Force du ressort fait face à l'opposé du bord de la charnière.  
 Potencia del resorte cara opuesta al borde del gozne.

**4. Install arm & shoe assembly onto frame.**

Installez l'assemblage du bras et de la console sur le cadre. Instale el ensamblaje del brazo y de la zapata en el cuadro.

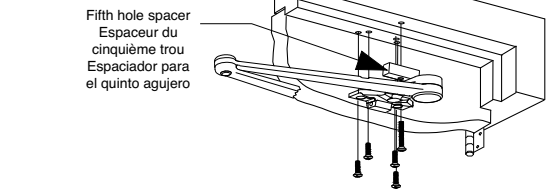

**HOLD OPEN ARM:** To engage or disengage hold open feature, turn control handle one-quarter (1/4) turn.

**BRAS DE RETENUE:** Pour engager ou désengager le mécanisme de retenue, tournez la manette de contrôle d'un quart (1/4) de tour.  
**BRAZO DE RETENCIÓN:** Para embragar o desembragar la característica de retención, dar un cuarto de vuelta (1/4) al cabo.

**5. Securely attach spring block to shoe.**

(Right hand shown)  
 Fixez solidement le bloc ressort au sabot (main droite illustrée)  
 Sujeta seguramente el bloque resorte a la zapata (Mano derecha ilustrada)

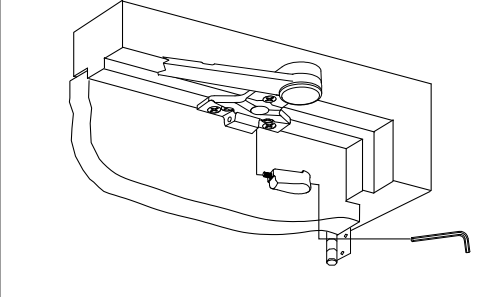

**6. Attach main arm to closer.**

Attachez le bras principal au ferme-porte. Coloque el brazo principal al cerrador.

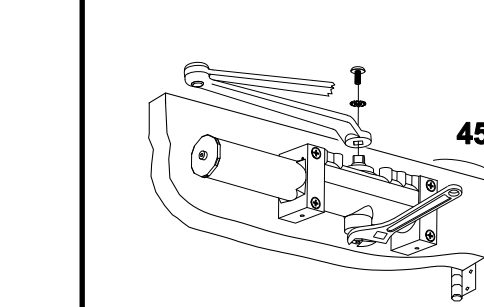

**8. Attach cover with screws and insert cover plugs.**

Fixez le couvercle avec les vis et insérez les bouchons de couvercle. Sujeta la tapa con las tuercas e inserte los tapones de tapa.

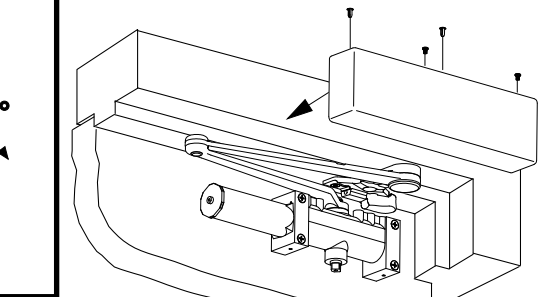

**7. Adjustment Instructions**

